



OWNER'S MANUAL

AccUView LED

UV Transmittance & Absorbance Monitor

HF scientific
3170 Old Metro Parkway
Ft. Myers, FL 33916
Phone: 239-337-2116
Fax: 239-332-7643
Toll Free: 888-203-7248
E-Mail: HF.Info@Wattswater.com
Website: www.hfscientific.com

Catalog No. 29173 (1/2020)
Rev 2

DECLARATION OF CONFORMITY

Application of Council Directive
Standards to Which Conformity is Declared:

Product Safety – Tested and passed:

Part 1: General Requirements UL61010-1 Issued May 11 2012 Ed 3 and CAN/CSA
C22.2 #61010-1 issued May 11 2012



Conforms to UL STD 61010-1
Certified to CSA STD C22.2 No. 61010-1

Emissions & Immunity – Tested and passed EN 61326-1:2013

Manufacturer's Name: HF scientific, inc.

Manufacturer's Address: 3170 Old Metro Parkway, Fort Myers, Florida 33916-7597

Importer's Name:

Importer's Address:

Type of Equipment: Process Turbidimeter

Model No: AccUView LED

Part Numbers 28041 & 28042 (with Flow Switch)

I, the undersigned, hereby declare that the equipment specified above conforms to the above Directives and Standards.

Place: Fort Myers, Florida USA

Date: 18 August, 2015

A handwritten signature in black ink that reads 'Mike Trammell'.

(Signature)

Mike Trammell,

Vice President of Product Development,
Watts Water Quality

Table of Contents

Section	Page
Specifications	1
1.0 Overview	2
1.1 Unpacking and Inspection of the Instrument and Accessories	2
1.2 The Display	3
1.3 The Touch Pad	3
1.4 Vapor Purge	4
2.0 Safety	4
3.0 Installation and Commissioning	5
3.1 Mounting and Site Selection	5
3.2 Plumbing	6
3.2.1 Pressurized Systems	7
3.2.2 Drain Vent	7
3.3 Electrical Connections	7
3.3.1 Power	8
3.3.2 RS-485	8
3.3.3 Relays	8
3.3.4 4-20 mA	8
4.0 Operation	9
4.1 Warm-up	9
4.2 Routine Measurement	9
4.3 Security Access Feature	10
4.4 Initial Operation	10
5.0 Instrument Calibration	11
5.1 100%T Calibration	11
5.2 ABS Calibration	12
5.2 Calibration Error	13
6.0 Restore Factory Settings	14
6.1 Restoring Factory Settings	14
7.0 Instrument Configuration (CONFIG mode)	16
7.1 Selecting the Output (O/P)	16
7.2 Setting the 4-20 mA	16
7.2.1 Setting the 4 mA Level	17
7.2.1 Setting the 20 mA Level	17
7.2.1 Setting the Error Level	17
7.3 Configuring the RS-485 Port	18
7.3.1 Setting the Baud Rate	18
7.3.1 Setting the Address	18

Table of Contents (continued)

Section		Page
7.4	Configuring the Alarms	19
	7.4.1 Alarm 1	19
	7.4.2 Alarm 2	20
7.5	Enabling the Security Access.....	21
7.6	Extended Settings.....	21
7.7	Units	21
7.8	Speed of Response	22
7.9	LCD Backlight Brightness.....	22
7.10	Ultrasonic Cleaning	22
7.11	RS-485 Parameter - Bits	23
7.12	RS-485 Parameter - Parity	23
7.13	RS-485 Parameter – Stop Bits	23
7.14	Duty Cycle	23
7.15	Desiccant Alarm.....	24
7.16	4 mA Adjustment.....	24
7.17	20 mA Adjustment.....	24
7.18	Saving Configuration Settings	25
8.0	Additional Features and Options	26
	8.1 Backlit LCD	26
	8.2 Ultrasonic Cleaning	26
	8.3 RS-485 Output	26
	8.3.1 HF Online.....	26
	8.3.2 Simple Communication	27
	8.3.3 Modbus Communication.....	27
	8.4 Flow Alarm	27
	8.5 Remote Panel Meter.....	27
9.0	Routine Maintenance	28
	9.1 Cleaning the Flow Through Cuvette.....	28
	9.2 Replacing or Installing the Desiccant Pouch	28
	9.3 Replacing the Source Lamp	28
10.0	Troubleshooting	29
	10.1 AccUView LED Fault Detection	29
	10.2 System Fail Message	29
	10.3 Diagnostic Chart	30
	10.4 Technical and Customer Assistance	30
11.0	Accessories and Replacement Parts List	31
12.0	Warranty	32

Specifications

Measurement Range	0 – 100.0 %T 0 – 2.0 ABS
Repeatability	± 1.0 %T ± 0.002 ABS
Resolution	0.1 % T 0.0004 ABS
Accuracy	± 2.0 % T ± 0.008 ABS
Response Time	Adjustable Averaging
Path Length	22 mm(Readings corrected to 10 mm)
Display	Multi-Line Liquid Crystal Backlit Display
Alarms	Two Programmable, 120-240VAC 2A Form C Relay
Analog Output	Powered loop isolator 4-20 mA, 600 Ω drive
Communications Port	Optional bi-directional RS-485 with Modbus
Maximum Water Pressure	1380 kPa (200 psi.) with integral pressure regulator
Flow Rate	100 ml/min. – 1.5 liter/min. (.026-.40 Gal/min)
Operating Temperature	0°C – 50°C (32°F – 122°F)
Wetted Materials	Nylon, Quartz, Silicone, Polypropylene, Stainless Steel
Sample Temperature Range	0°C – 50°C (34°F – 122°F)
Power Supply	100– 240 VAC, 47 – 63 Hz, 80VA
Insulation Rating	Double Insulated, Pollution Degree 2, Overvoltage Category II
Environmental Conditions	Not recommended for outdoor use. Altitude up to 2000 meters Up to 95 % RH (non-condensing)
Enclosure	ABS
Regulatory Compliance And Certifications	CE Approved, Listed to UL 61010-1 3 rd edition: 2012 Certified to CAN/CSA C22.2 No. 61010-1: 2012 EMC: EN61326-1: 2013
Shipping Weight	2.5 kg (5.5 lbs.)
Warranty	1 Year from date of shipment

1.0 Overview

The AccUView LED process transmittance monitor allows for the UV transmittance or absorbance measurement of process water on-line.



A unique feature of the instrument is the ultrasonic cleaning. Refer to section 8.2 for more information.

1.1 Unpacking and Inspection of the Instrument and Accessories

The table below indicates the items in the monitor shipment.

Item	Quantity
AccUView LED Monitor c/w Field Terminal Box & Flow Through Assembly	1
Instruction Manual	1
Desiccant Pack	1
Quartz Cuvette with Ultrasonic Transducer (Single Pack)	1
100 % T Calibration Standard	1
Tubing Kit *	1

* Note - Tubing Kit includes:

- 1-shutoff clamp
 - 1-backpressure valve
 - 2-connecting tubings with fittings for flow through assembly
 - 1-drain vent screw (used in pressurized systems)
- Refer to Figure 4.

Remove the instrument from the packing carton. Carefully inspect all items to ensure that no visible damage has occurred during shipment. If the items received do not match the order, please immediately contact the local distributor or the HF scientific Customer Service department.

1.2 The Display

Figure 1 illustrates all the items that can appear on the display. The upper row of the display (1) is used for reporting the % T levels and to provide user guidance in the customer setting routine. The lower row of the display (2) is used to communicate error messages and provide user guidance. All error messages will be added to a queue along with the units (%T). The display has two icons (3) that are used to indicate the use of access code and offset mode. In addition, mode arrows (4) are used to indicate the current instrument operating mode; AUTO (normal operation), CAL (calibration) and CONFIG (configuration).

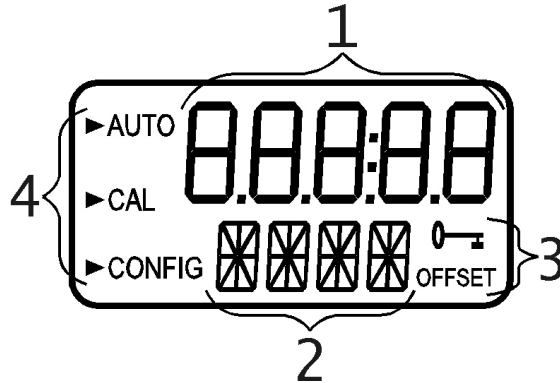

Figure 1 – Display used in the instrument.

All items used on the display are shown in this figure

1.3 The Touch Pad

Figure 2 illustrates the touch pad. The touch pad has four buttons: **MODE/EXIT**, \swarrow , \blacktriangle , and \blacktriangledown . The **MODE/EXIT** button is used to cycle between the three operational modes of the instrument: **CAL**, **CONFIG**, and **AUTO** (Measurement) mode. The \swarrow button enters the option (or mode that is highlighted or chosen. The \blacktriangle and \blacktriangledown buttons are used to change settings.

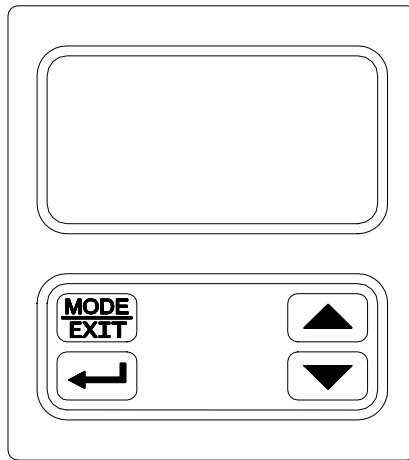

Figure 2: The AccUView LED touch pad.

1.4 Vapor Purge

The AccUView LED is equipped with a continuous vapor purge system. A replaceable desiccant pouch in the lower portion of the instrument dries the air. System heat is used to warm the air. A fan inside the instrument continuously circulates heated dry air around the optical well and the flow through cuvette. This feature eliminates the need for a dry purge line.

The AccUView LED monitors the replaceable desiccant pouch condition continuously. The LCD display will show **DESC** on the lower line in the event that the desiccant pouch needs replacement. Replacement desiccant pouches are available from HF scientific, or the local representative (Part # 21555R). Refer to section **9.2 Replacing or Installing the Desiccant Pouch**



2.0 Safety

This manual contains basic instructions that must be followed during the commissioning, operation, care and maintenance of the instrument. The safety protection provided by this equipment may be impaired if it is commissioned and/or used in a manner not described in this manual. Consequently, all responsible personnel must read this manual prior to working with this instrument.

In certain instances icons or symbols have been added to give further clarification to the instructions. Refer to the *Table of Contents* to easily find specific topics and to learn about unfamiliar terms.

2.1 Symbols Used in this manual



This symbol identifies hazards which, if not avoided, could result in minor or moderate injury or damage to the equipment.



This symbol identifies important information, practices or actions.



This pictorial alert you to the need read the manual, possibly at a different section.



This pictorial alerts you to electricity, electrocution and shock hazards.

3.0 Installation and Commissioning



Prior to use for the first time, the supplied desiccant pouch will need to be installed. Refer to section [9.2 Replacing or Installing the Desiccant Pouch](#).

3.1 Mounting & Site Selection

The instrument is designed for wall mounting. For ease of service there should be about 20 cm (8") free area above the instrument; this will ensure enough room for calibration and cuvette maintenance. Choose a location that is easily accessible for operation and service and ensure that the front display rests at eye level. The overall mounting dimensions of the instrument are shown in Figure 3. The recommended mounting screws are M6 (1/4") for the instrument enclosure and M4 (3/16") for the field terminal box. The AccUView LED is designed to have the field terminal box cradled under the sensor portion of the instrument. It is recommended that the field terminal box be mounted first, and then the rest of the instrument be mounted on top. The template included on the last page of this manual may be used to establish mounting-hole locations.

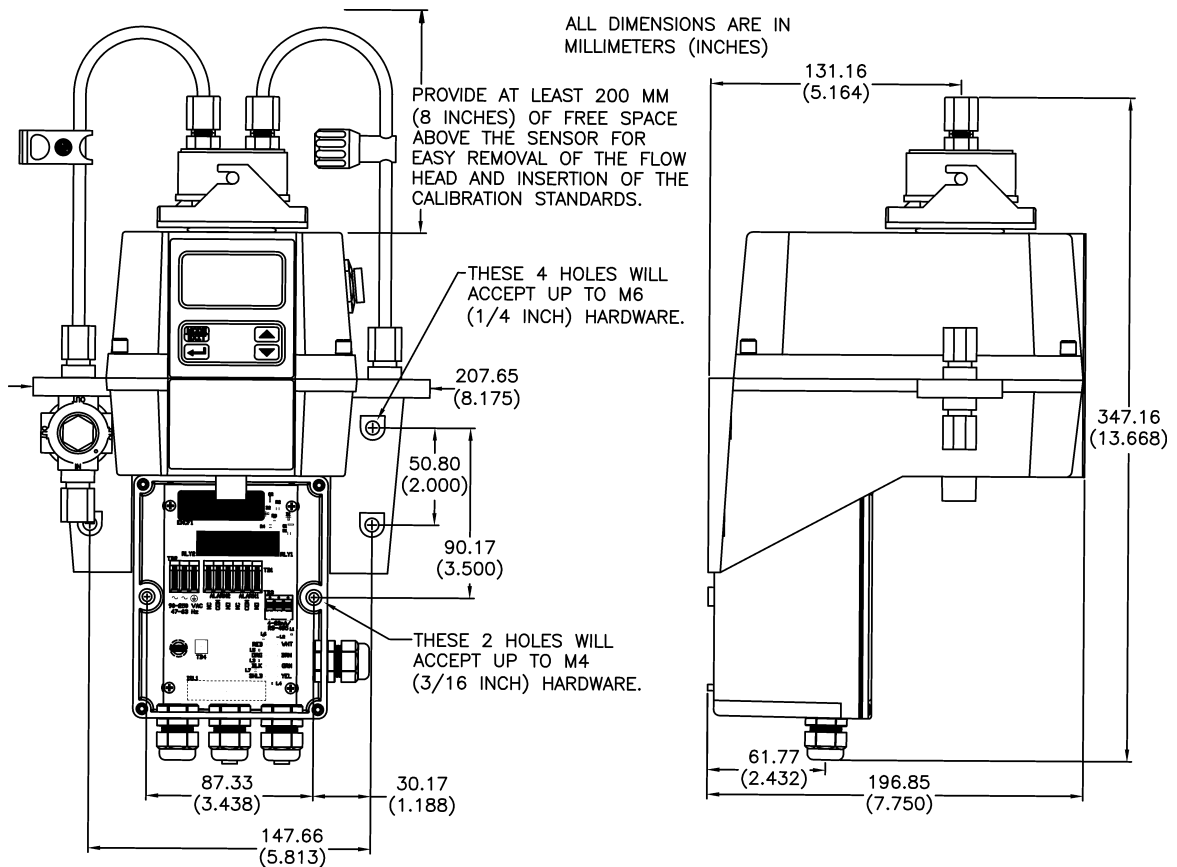

Figure 3: Overall Mounting Dimensions of the Instrument

It is critical that the instrument be mounted as close as possible to the sampling point to ensure a quick response time (within 2-3 meters (6-10 ft) of the sampling point).

3.2 Plumbing

The recommended plumbing for the instrument is shown in Figure 4. The instrument is designed to require very little head pressure to operate; around 6.9kPa (1 PSI). Flow requirements are 100ml/min. – 1.5 liter/min. (0.026-0.40Gal/min). The pressure regulator will allow for a maximum pressure of 1380kPa (200 PSI.). The maximum allowable fluid temperature is 50°C (122°F).

An optional flow regulator Cat# 19778 can limit flow to around 1 liter/min. this is not recommended for applications involving sea water.

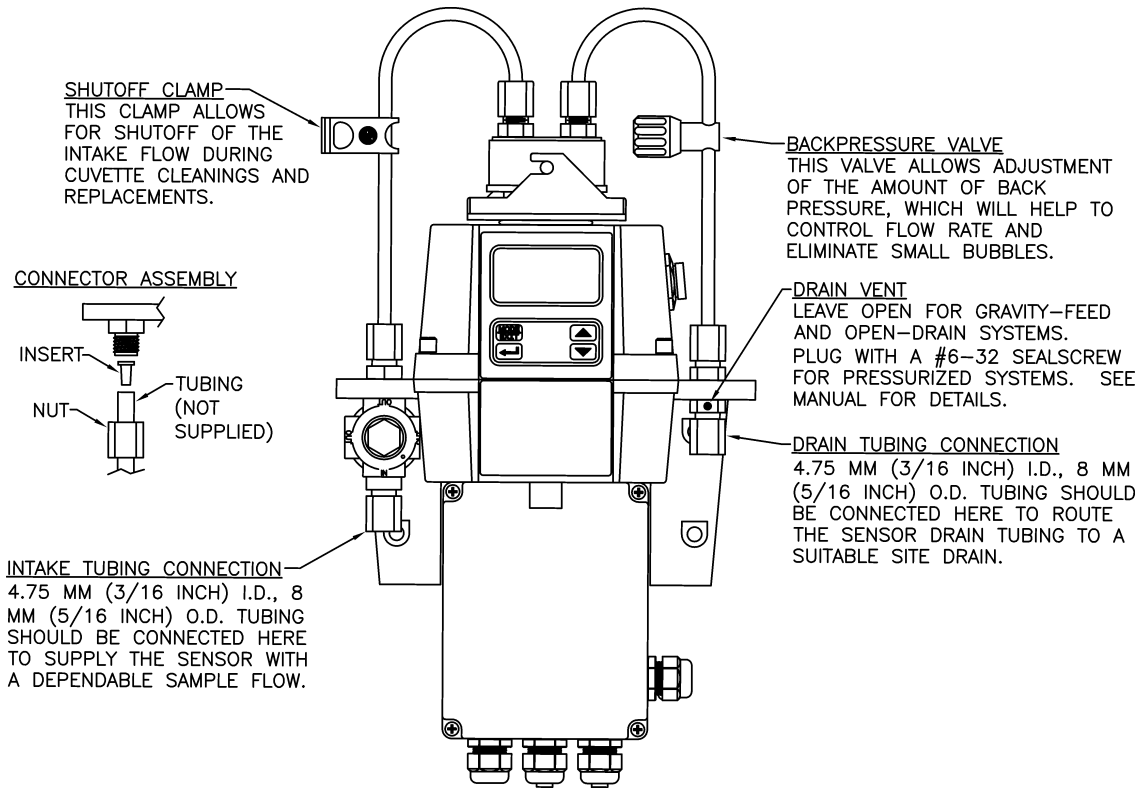

Figure 4: Recommended Plumbing for the Instrument

The instrument is equipped to be plumbed using 4.75 mm (3/16") ID, 8 mm (5/16") OD flexible tubing. Opaque tubing should be used if the tubing will be exposed to sunlight, to prevent algae growth.

NOTICE

Model 28042 is equipped with a flow switch. For this instrument the user connections are equipped with 1/4" push-to-connect connections. The suitable tubing is polymer or copper tubing with a 1/4 inch OD. These connectors cannot be used with stainless steel tubing.

In figure 4, there are two operator controlled flow adjustment devices shown. The one on the input side is a shutoff clamp used during cuvette maintenance. The other device, located on the output side of the flow cell, is a backpressure valve. Backpressure may be required to prevent air from coming out of solution, which may be observed as tiny air bubbles.

3.2.1 Pressurized Systems: A standard feature of the AccUView LED is a pressure regulator. The regulator is rated for use up to 1380 kPa (200 PSI) and will lower the pressure down to a pressure more suitable for use in the AccUView LED. If inlet pressures can exceed 325 kPa (47 PSI) use appropriate tubing to connect to the AccUView LED. An optional flow regulator can be used to limit the flow to 1 liter per minute.

3.2.2 Drain Vent: The AccUView LED has been fitted with a drain vent in the “OUT” bulkhead fitting. This fitting allows for atmospheric equalization, thus helping to alleviate bubble formation in the cuvette. Refer to Figure 4.

Upon initial flow minor leakage may occur through the drain vent. This will subside once normal flow is established.

For some high pressure systems, where the vent hole continuously leaks, a 6:32 seal screw is provided which should be inserted into the vent hole and tightened.

NOTICE

The drain water from this instrument should NEVER be reintroduced back into the incoming water stream. This water MUST be directed to a convenient drain.

3.3 Electrical Connections

All of the electrical connections to the instrument are made through the field terminal box, which should be located directly under the sensor portion of the instrument. The connections are labeled within the terminal box and are self-descriptive (see Figure 5). Please follow all local and government recommendations and methods for installation of electrical connections to and between the instrument and other peripheral devices.

Plugs are inserted into the alarm and 4-20mA/RS-485 cable bulkheads when shipped, to ensure a watertight seal. These plugs should be removed and discarded when cabling to either of these connections.

The power cable bulkhead will accept cable diameters from 5.8mm (.230 in.) up to 10 mm (.395 in.). All terminals are designed to accept wires in the range of 14-28 AWG. All wires should be stripped to a length of 6 mm (¼”). A strain relief strap is provided to reduce tension on the power terminals.

It is the user’s responsibility to assure that the watertight seal is maintained after the terminal box has been wired for operation. If any of the bulkheads are not tightened properly around a cable or plug, the ratings of the instrument will be jeopardized and there is a possibility of creating a shock hazard.

Only qualified electricians should be allowed to perform the installation of the instrument as it involves a line voltage that could endanger life.



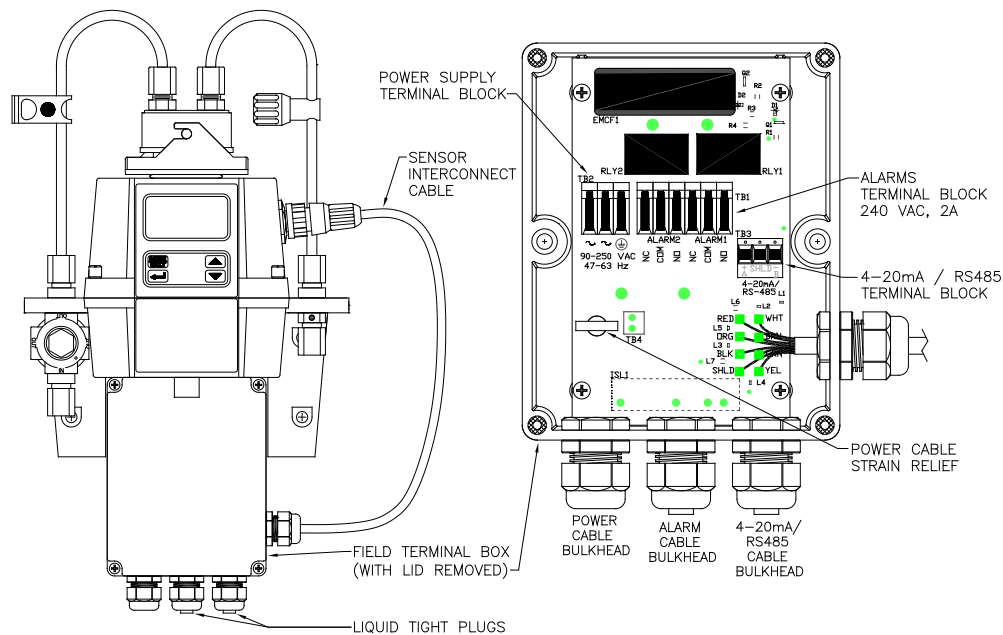

Figure 5: Electrical Connections for the Instrument

3.3.1 Power: The instrument is equipped with a 100-240 VAC, 47-63 Hz switching power supply; please verify that the line voltage falls within these specifications. It is recommended that a circuit breaker be placed prior to the power connection to allow for service. While making connections, refer to Figure 5. **The AccUView LED is not supplied with a power cord.**

3.3.2 RS-485: The RS-485 Modbus or special protocol half-duplex (2-wire) digital interface operates with differential levels that are less susceptible to electrical interferences. This is why cable lengths up to 3000 ft can be implemented. The last device on each bus may require terminating with a 120-ohm resistor to eliminate signal reflection on the line. Do not run RS-485 cables in the same conduit as power.

To prevent damage to the instrument, ensure that power is disconnected prior to making connections. For ease of connecting, remove the plug in terminal block. Connections are labeled beneath this termination.

3.3.3 Relays: The Alarm 1 and Alarm 2 relays are mechanical relays rated at 240 VAC 2A. Please note that the relays are labeled NO (Normally Open), NC (Normally Closed) and C (Common). As these alarms are configured fail-safe, the normal condition is with power applied to the AccUView LED and in a non-alarm condition. Operation of these alarms is covered in section **7.4 Configuring the Alarms**.

3.3.4 4-20 mA: The 4-20 mA output is driven by a 15 VDC power source and can drive recorder loads up to 600 ohms. Do not run 4-20 mA cables in the same conduit as power. Operation of this output is covered in section **7.2 Setting the 4-20 mA**. The outputs are equipped standard with an installed loop powered isolator (500V isolation).

To prevent damage to the instrument, ensure that power is disconnected prior to making connections. For ease of connecting, remove the plug in terminal block. Polarity of the connections is labeled beneath this termination.



4.0 Operation

This process monitor allows for the measurement of the transmittance of process water on-line. Process water is usually reported in units of %T. Readings above 102 %T are indicated by a flashing display. Readings above 100 %T indicate that the current sample is better than the calibration water. Readings above 110 %T are not possible. All readings are path length corrected to 10 mm.

Alternately measurements can be taken in Absorbance. Negative Absorbance readings indicate the need for a calibration or that the water tested is better than what the instrument was calibrated to. These readings show ABS on the lower line of the display. All readings are path length corrected to 10 mm.

During normal operation, the instrument will have the arrow beside **AUTO**. The scale (% T or ABS) is displayed on the lower row of the display and the measured reading on the upper row of the display (see illustration below). The user needs to keep in mind that the instrument only updates at periods determined in the configuration or **CONFIG** menu. Refer to section **7.14 Lamp Duty Cycle**.

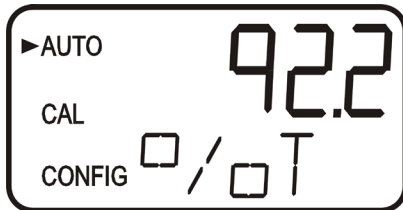

4.1 Warm-up

Upon power-up the AccUView LED will require a warm-up period of about 30 minutes. For improved accuracy, allow the AccUView LED to complete warm-up time prior to calibrating. During the warm-up period, the display may flash indicating that it has detected a temperature change. It is normal for this to occur during the warm-up period.

4.2 Routine Measurement

The following steps describe how to measure the % T or ABS of a sample using this instrument:

1. Apply power to the instrument and allow the unit an initial warm up of 30 minutes.
2. When a continuous process stream is flowing through the instrument, the instrument will display the measured % T or ABS level of the sample by displaying it on the LCD screen. In addition, the equivalent signal is provided on the analog (4-20 mA) output, or the digital output, depending on the options selected.

NOTICE

A flashing display may occur after warm-up. This is an indication that either the ambient or the water temperature or has changed rapidly. During this time the readings may be slightly out of the specified accuracy. The AccUView LED will automatically compensate as soon as the rate of temperature change slows.

4.3 Security Access Feature

The instrument is equipped with a security access code feature that can be activated in the configuration mode. If the security feature is enabled, the screen shown in the illustration below will appear when the **MODE/EXIT** button is pressed.

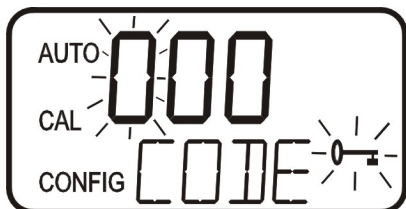

The security code (333) must be entered to gain access to **CAL** or **CONFIG** menus. Notice that the first number in the code is flashing. The flashing indicates that this is the number to be entered. Use the \blacktriangle or \blacktriangledown arrows to select the first of the three numbers in the code and then press the \blacktriangledown button to accept the first number of the code. Now enter the second number in the code. Proceed as with the first number followed by \blacktriangledown . Then repeat the process for the third number in the access code, and finish with the \blacktriangledown button.

If the valid access code has been selected, the instrument will be directed to the calibration mode. If the CONFIG mode is needed push the MODE/EXIT button one more time.

If the wrong access code is selected, the instrument will return to the **AUTO** mode. Refer to section [7.6 Enabling the Security Access](#) for more information.



4.4 Initial Operation

It is recommended to check that cuvette is tightly installed on the flow through unit prior to the introduction of water. These are pressure checked at the factory but due to shipping the cuvette could have loosened.

For the best accuracy an initial calibration is recommended. These are all factory calibrated but the best accuracy is achieved by calibrating with DI water with the flow through locked in place prior to calibration. Do not move the flow through after calibration, but simply start the fluid flow. Refer to the next section for complete calibration instructions.

5.0 Instrument Calibration

The instrument was calibrated and tested prior to leaving the factory. Therefore, it is possible to use the instrument directly out of the box. Under normal conditions, re-calibration is recommended at least once every month. To get the greatest accuracy, you may need to calibrate once per week.

Two cuvettes are supplied with the instrument so that they can be exchanged with each other. One cuvette should always be kept clean for replacement when calibrating.

The instrument is designed to store the last reading prior to calibrating. Relay contacts are held at the last valid condition and will not change state while the instrument is in the calibration mode. The 4-20 mA is also held at this stored reading and will not change until calibration is complete. Thirty seconds after completion of the calibration the AccUView LED will start taking online measurements which will be averaged with the stored reading (depending on setting). In order to prevent disruptions in data the operator should release the clamp to allow the sample water to flush out the calibration water as soon as the calibration is completed.

While in the calibration mode, the instrument has a time-out feature that automatically returns the system operation to the **AUTO** mode after a fifteen (15) minute period of inactivity.

5.1 100 %T Calibration

NOTICE

Before starting the calibration procedure, be sure to turn off the instrument's ultrasonic cleaning option. See section 7.10 for instructions.

1. Select the calibration function of the instrument by pressing the **MODE/EXIT** button once. The arrow beside **CAL** will be illuminated on the display. The lower display shows alternating **100** (indicating that the 100%T standard is requested) and \downarrow . The last reading has now been stored and the equivalent reading is being output on the 4-20mA signal. This output will be held after the instrument returns to **AUTO**, allowing time for the flow to be restarted.
2. Close off the flow of water using the shutoff clamp.

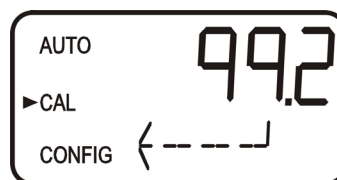
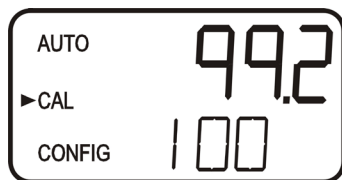

3. Remove the flow through cuvette, and retain for future cleaning and use.
4. Fill the second clean cuvette with 100% T calibration fluid and reinstall the filled cuvette tightly on the flow through unit.
5. **Wipe flow through unit dry**, install and lock in place.
6. Press the \downarrow button to start the calibration.
7. The upper display will count down the progress of the calibration step.
8. The instrument will return to **AUTO** mode at the end the calibration.
9. The shutoff clamp should now be released to restore sample flow.
10. **Do not move flow head after calibrating.**

NOTICE

5.2 ABS Calibration

Before starting the calibration procedure, be sure to turn off the instrument's ultrasonic cleaning option. See section 7.10 for instructions.

1. Select the calibration function of the instrument by pressing the **MODE/EXIT** button once. The arrow beside **CAL** will be illuminated on the display. The lower display shows alternating **0** (indicating that the 0.000ABS standard is requested) and \downarrow . Once in the calibration menu the last reading has now been stored and the equivalent reading is being output on the 4-20mA signal. This output will be held after the instrument returns to **AUTO**, allowing time for the flow to be restarted.
2. Close off the flow of water using the shutoff clamp.

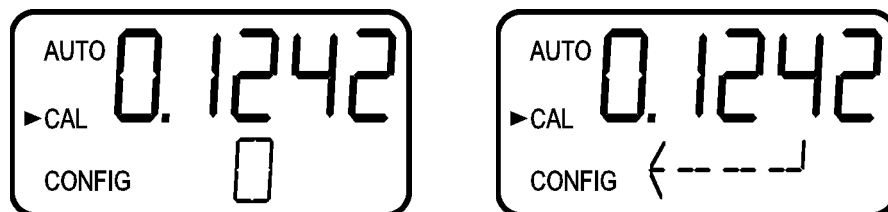

3. Remove the flow through cuvette, and retain for future cleaning and use.
4. Fill the second clean cuvette with 100% T/0.000 ABS calibration fluid and reinstall the filled cuvette on the flow through unit.
5. **Wipe flow through unit dry**, install and lock in place.
6. Press the \downarrow button to start the calibration.
7. The upper display will count down the progress of the calibration step.
8. The instrument will return to **AUTO** mode at the end the calibration.
9. The shutoff clamp should now be released to restore sample flow.
10. **Do not move flow head after calibrating.**

Since the instrument stored the reading previous to calibration, the previous reading may appear after calibration for at least 30 seconds. The reading will then update to the current reading. How fast this upgrades occurs depends on the **CONFIG** settings for **RESP** (response time) and **UV-T** (lamp duty cycle).

There is no need to recalibrate when changing ranges from %T to ABS or the reverse.

NOTICE

It is recommended that the flow through unit be removed for as short an interval as possible to prevent premature saturation of the desiccant.

CAUTION

The UV lamp is of very low power but is recommend to avoid looking directly into the optical well while the flow through unit is removed.

5.3 Calibration Error

If the screen shown below is displayed after the 100%T or 0 ABS calibration, the internal diagnostics have determined that the calibration fluid requires replacement or the flow through cuvette requires replacement. Check, the calibration fluid & cuvette, then recalibrate or restore the factory calibration see [6.1 Restoring Factory Settings](#). The instrument cannot be used without performing one of these operations.



To recalibrate press the MODE key and start the calibration sequence again. To restore the factory calibration, push and hold the \blacktriangle button. Now push and release the \blacktriangledown then release the \blacktriangle button.

6.0 Restore Factory Settings.

6.1 Restoring Factory Settings

If the instrument is unable to perform a calibration due to a low lamp output, bad calibration standard or a dirty cuvette, the instrument will display **CAL** on the lower row of the display and **Err** on the upper row. The operator has two choices to correct this problem or restore the factory calibration. If the operator can determine whether a poor calibration or a low lamp caused the problem, he/she can remedy the problem and recalibrate. If all else fails, the operator may restore the factory calibration and configuration settings by performing the following operation. Push and hold the **▲** button. Now push and release the **↵** then release the **▲** button. Factory calibration and factory configuration have now been restored.

NOTICE

Restoring the factory settings allows the use of the AccUView LED with reduced accuracy. The original problem still exists and must be determined and corrected before accurate operation of the AccUView LED will be resumed. The AccUView LED will always reset to %T and factory defaults after restoring.

7.0 Instrument Configuration (CONFIG mode)

The instrument has been designed to provide the ability to customize the instrument according to needs at any time during normal operation. This mode has been split into sub-menus to facilitate instrument configuration. This section describes how to use each of the sub-menus to configure the instrument. While in the configuration mode, the instrument has a time-out feature that automatically returns the system operation to the **AUTO** mode after a fifteen (15) minute period.

Enter the **CONFIG** mode of the instrument by pressing the **MODE/EXIT** button until the arrow beside **CONFIG** is illuminated, then press the \downarrow button.

NOTICE

To exit the **CONFIG** mode, press the **MODE/EXIT** button.

7.1 Selecting the Output (O/P)

The first configuration selection is the **O/P**. The selections are:

1. **4-20** for the 4-20 mA output
2. **485** for the RS-485 and modbus
3. **OFF** if no outputs are required.

Select the desired output by using the \blacktriangle and \blacktriangledown buttons. Once the desired output has been set, press the \downarrow button to accept it. The next prompts will depend on the output selected.

7.2 Setting the 4-20 mA

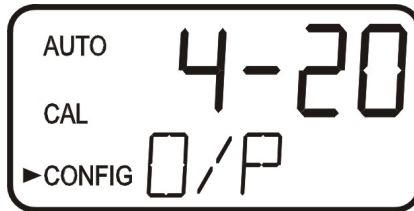

If the 4-20 mA output was turned on, prompts to set the 4mA (**4MA**) and 20mA (**20MA**) %T or ABS limits levels will be displayed. There is also a menu to adjust the error level (**ERLV**). The first prompt will be the %T or ABS limit assigned to the 4 mA output level:

7.2.1 Setting the 4 mA Level

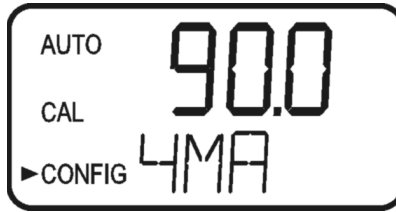

Select the %T or ABS level to assign to the 4MA using the ▲ and ▼ buttons. The factory setting is 90%T or.

Once the desired level has been set, press the ↵ button to accept it.

The factory default setting for %T is 90%T and the for ABS is 0

NOTICE

The 4MA cannot be set higher than the 20 MA level.

7.2.2 Setting the 20 mA Level

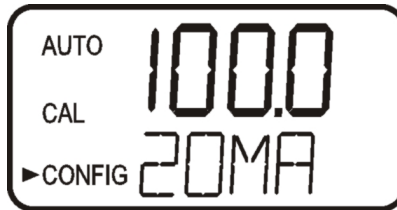

The next, prompt will be the %T or ABS level assigned to the 20 mA output level (**20MA**) on the lower row of the LCD display). Select the %T level to assign to the **20MA** using the ▲ and ▼ buttons. Once the desired level has been set, press the ↵ button to accept it.

The factory default setting for %T is 100%T and for ABS is 2.

NOTICE

The 20 MA cannot be set lower than the 4 MA level.

7.2.3 Setting the Error Level



In case of an error in the AccUView LED, the 4-20 mA reading can be used to indicate a problem by sending the output to either:

1. 4.00 mA,
2. 2.00 mA
3. 0 mA
4. OFF. In the case of OFF, the 4-20mA is unaffected by any error condition.

The factory default setting is OFF. Select the desired ERLV by using the ▲ and ▼ buttons then press the ↵ button to accept the desired error response.

7.3 Configuring the RS-485 Port

If the instrument is wired for this option, and the I/O selection is changed to **485**, prompts will appear for setting the baud rate and the address.

7.3.1 Setting the Baud rate

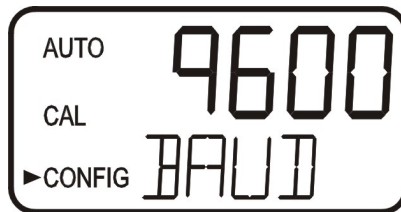

Select the correct baud rate (1200, 2400, 4800, 9600, or 19200) for operation of the I/O port by pressing the \blacktriangle or \blacktriangledown buttons to change the displayed baud rate.

The factory setting is 9600 baud.

Press the \blacktriangledown button to continue on and select the desired instrument address using the \blacktriangle or \blacktriangledown buttons. Once the selection is satisfactory, press the \blacktriangledown button.

7.3.2 Setting the Address



The last selection is the address. This Address is important where multiple instruments are wired on a single string. Each instrument **MUST** have a unique Address.

The factory setting is Address 1

To enable the Modbus mode, select **ASCII** or **RTU**. For more information refer to the Modbus Manual. The manual is also available as a free download from our website at www.hfscientific.com.

7.4 Configuring the Alarms

Two relays are provided that are designed to operate as two independent programmable alarms. Three types of information must be input to fully program each alarm:

1. The alarm function (HI, LO, OFF or Error)
2. The alarm set point (level at which the alarm activates)
3. The delay time for the alarm: the time that the set point must be exceeded prior to alarm activation and the time before resetting the alarm (prevents chatter in the relay)

These three items are described below:

Alarm Function: The alarms can either be turned OFF or programmed to operate in one of three different manners:

1. HI alarm: the relay changes state when the measured %T or ABS level is higher than the programmed alarm level for a prescribed amount of time.
2. LO alarm: the relay changes state when the measured %T or ABS level is lower than the programmed alarm level for a prescribed amount of time.
3. Error: the relay changes state when a system error occurs. If a system error occurs a message will appear on the lower row of the screen describing the problem.

Alarm Set Point: The level at which an alarm activates is called the alarm set point. On the instrument, the alarm set point is designated as “S/P”. The set point is adjustable to any valid %T or ABS level over the range of the instrument in steps of 0.01 NTU.

Alarm Delay Time: The alarm delay times are used to prevent ringing of the alarm when the measured %T or ABS level is close to the set point. The function of the delay times is as follows:

Delay On: The %T or ABS level must exceed the alarm set point continuously for at least this number of seconds before the alarm activates.

If the delay on time is set at 5 seconds and the process %T or ABS exceeds the set point continuously for only 4 seconds, the alarm will not be activated. However, process %T or ABS exceeds the set point continuously for 5 seconds or more, the instrument will activate the alarm.

Delay Off: The %T or ABS level must not exceed the alarm set point continuously for at least this number of seconds prior to deactivation of the alarm.

If the delay off time is set to 5 seconds and the process has exited out of the alarm condition, the alarm will be reset only if the process is out of the alarm condition for a continuous 5 seconds. Otherwise, the instrument will still signal an alarm condition.

7.4.1 Alarm 1

Alarm 1 Function: The **ALM1** is displayed and the display indicates the current function of alarm 1 (**HI, LO, OFF** or **Error**). Use the **▲** or **▼** buttons to cycle through and select the desired function. Press the **↵** button to accept the selection.

If the alarm was turned **OFF** a prompt will appear to set up alarm 2 (go to section **7.4.2**). If, on the other hand, one of the other functionalities was selected a prompt will appear to set the delay times.

Alarm 1 Set Point: This prompt is used to select the set point for this alarm; this is indicated by “S/P” shown on the lower row of the display. Select the desired alarm level by using the ▲ and ▼ buttons. Once the desired set point has been set, press the ↵ button to accept it.

Alarm 1 Delay Times: Delay On: The following display will appear to allow to select the number of seconds currently set for the “delay on” time.

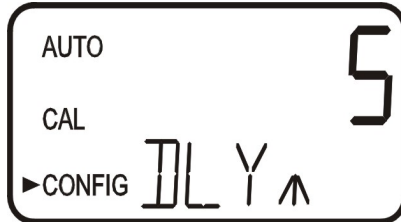

The current selected number of seconds will be shown. Select the desired number of seconds for the “delay on” time for this alarm using the ▲ and ▼ buttons. Once the desired delay time has been set, press the ↵ button to accept it.

Delay Off: Next, the following display will appear to select the number of seconds currently set for the “delay off” time.



The current selected number of seconds will be shown. Select the desired delay off time for this alarm using the ▲ and ▼ buttons. Once the desired delay time has been set, press the ↵ button to accept it. After the settings for alarm 1 have been completed, prompts will allow for the set up of the information on alarm #2.

7.4.2 Alarm 2

Repeat the procedure listed in section 7.4.1 to set up the parameters for alarm 2. If one of the other functionalities is selected, a prompt to set the delay times and the set point, as with Alarm #1, will be displayed.

7.5 Enabling the Security Access

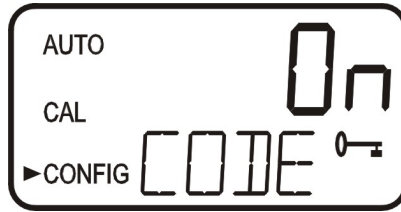

The instrument is equipped with a security access. If this option is turned on, the user is required to input the access code into the instrument to get to any mode other than **AUTO**. The only code is **333**. This code may not be changed. See section [4.3](#) for more information on this security feature. The security key icon will be visible and flashing on the display whenever the access option is selected using the \blacktriangle or \blacktriangledown buttons. (**On** or **OFF**).

7.6 Extended Settings

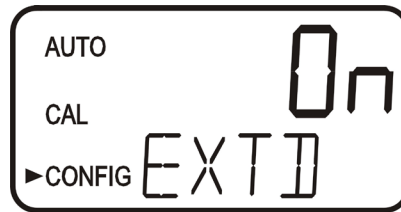

The last few settings are grouped together to prevent them from being adjusted by accident. To gain access to the extended settings, select **On** using the \blacktriangle or \blacktriangledown buttons and press the \blacktriangledown button.

7.7 Units

Select the preferred measurement parameter in either ABS shown or %T. This selection will affect menus prior Extended Settings.

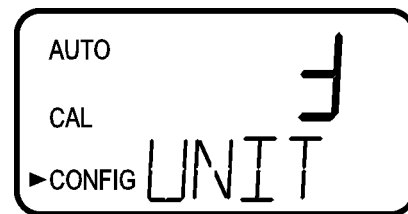
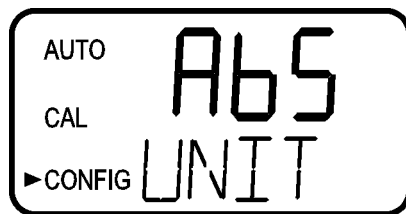

7.8 Speed of Response



The speed of response for both displayed and output values can be adjusted in this menu. The factory setting is 3 however, 10 response speeds are available. Select the desired speed of response using the \blacktriangle and \blacktriangledown buttons. Press the \blacktriangledown button to accept it.

Please note that the response is simply an average of the previous readings combined with the current reading. If the setting is 1, only current readings are displayed. If the setting is 10, the last 9 readings are averaged with the current reading.

7.9 LCD Backlight Brightness



The LCD backlight brightness may need to be adjusted. This is of particular interest if multiple instruments are located in the same area and it is desired for the entire group to have the same appearance. Ten levels are available. The factory brightness is 8.

Change the brightness by pressing the \blacktriangle or \blacktriangledown button. When the desired brightness has been selected, press the \blacktriangledown button.

7.10 Ultrasonic Cleaning



This allows for a selection menu to turn **OFF** the ultrasonic cleaning function if desired. The default mode is **On**. Make a selection using the \blacktriangle and \blacktriangledown buttons then press the \blacktriangledown button.

7.11 RS-485 Parameter - Bits

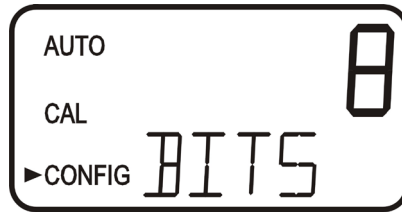

This is the first of three menus to setup the RS-485 parameters. These menus will only appear if the RS-485 mode is selected. Selections are 7 or 8 bits. The factory selection is 8 bits. Make a selection using the \blacktriangle and \blacktriangledown buttons then press the \blacktriangledown button.

7.12 RS-485 Parameter – Parity



In the Parity menu selections are no parity (nOnE), odd parity (Odd) or even parity (E). The default selection is no parity. Make a selection using the \blacktriangle and \blacktriangledown buttons then press the \blacktriangledown button. The factory setting is no parity.

7.13 RS-485 Parameter – Stop Bits



For stop bits the choices are 1 or 2 stop bits. The default selection is 1 stop bit. Make a selection using the \blacktriangle and \blacktriangledown buttons then press the \blacktriangledown button. The factory setting is 1 stop bit.

7.14 Duty Cycle

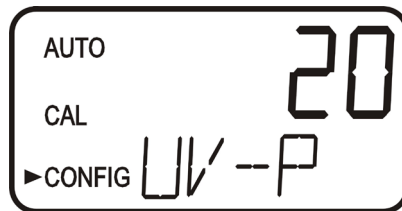

This determines how often the lamp turns on and updates the reading. The lamp will operate for 1 second each time to obtain readings. Updates can be set from 4 seconds to 60 seconds. The factory setting is 6. Keep in mind that this setting also affects the life of the LED. With updates set to 4 seconds the LED life is about four years. The factory 6-second update will extend the LED life to over 5 years. The 60-second setting increases LED life to about 14 years, but this will delay all updates.

Change the selected update period using the \blacktriangle and \blacktriangledown buttons then press the \blacktriangledown button.

7.15 Desiccant Alarm



When the humidity detector in the AccUView LED indicates that the internal environment is close to the point where humidity could cause condensation, the instrument will display **DESC** as a warning. If desired, a desiccant warning can activate the alarms and send the 4-20mA to 2mA. To activate the alarms when the desiccant fails, select **On** in the **DESC** menu. The default for this menu is **OFF**. Make selections using the ▲ and ▼ buttons then press the ↵ button to move to return to **AUTO** mode.

7.16 4mA Adjustment

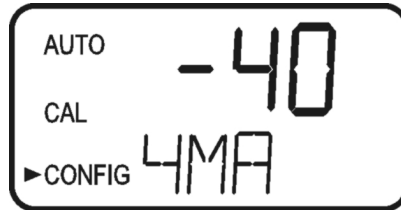

If the 4-20 mA setting is turned ON ([7.2 Setting the 4-20 mA Output](#)), the following two menus will appear. The first menu outputs a constant 4 mA while allowing for a small amount of adjustment. The adjustment can be made using the ▲ and ▼ buttons. This adjustment will allow the operator to make the AccUView LED agree with a PLC or SCADA system. The adjustment limits are ± 200 counts or about ± 0.2 mA.

This setting will be slightly different on each instrument as each AccUView LED will be factory set to 4.00mA. Press the ↵ button when adjustments are complete to save this setting and move on to the 20mA adjustment.

7.17 20mA Adjustment



This menu operates similar to the previous menu. This menu outputs a constant 20 mA while allowing for a small amount of adjustment. The adjustment can be made using the ▲ and ▼ buttons. The adjustment limits are ± 1000 counts or about ± 1 mA.

This setting will be slightly different on each instrument as each AccUView LED will be factory set to 20.00mA.

7.18 Saving Configuration Settings

If extended settings is set to **OFF**, pressing the ↵ button will save all settings and the AccUView LED will automatically return to the normal **AUTO** mode of the instrument.

If extended settings is set to **On**, after the last menu of the extended settings, pressing the ↵ button will save all settings and the AccUView LED will automatically return to the normal **AUTO** mode of the instrument.

The **CONFIG** menu may be used at any time to reset or change any of the parameters. The **CONFIG** menu may be exited at any point in the menu by using the **MODE/EXIT** key. Any features that have been modified will be saved.

While the operating in **CONFIG** mode the reading before entering that mode is held.

8.0 Additional Features and Options

8.1 Backlit LCD

The backlit LCD allows for easier readability of the LCD display in low light or no light conditions. The backlight is intended for continuous operation. The brightness is adjustable from a menu in the **CONFIG** mode.

8.2 Ultrasonic Cleaning

This option is used to continuously clean the flow through cuvette. It is not intended to clean cuvettes that are already dirty, or replace manual cleaning entirely. The system will increase the time between cleanings dramatically. Please note that the system requires the use of a special cuvette. This cuvette must be used for the system to operate correctly.

The system works by sending an ultrasonic frequency through spring connections into a piezo transducer bonded to the bottom of a flow through cuvette.

The system can detect that an incorrect cuvette is installed, an error has occurred in the transducer or the transducer is not making contact with the spring connections. This error is indicated by **CLN** being posted to the lower screen. Since this is an error condition, the alarms will be set and the 4-20 mA will be sent to 2 mA.

If the correct cuvette is installed, and the error is still posted, try rotating the flow through unit slightly to improve the connection. If this fails to work, the cuvette may have to be replaced (Catalog #24232S). The detection for this cuvette only operates in **AUTO** mode. If the system is operating correctly **AUTO** will flash.

After installing a cuvette, there will be a 30 minute period where the ultrasonic circuit will not operate to allow the Vapor Purge system to remove all moisture from the ultrasonic transducer.

Even with the above drying system, it is still recommended that Ultrasonic cuvettes be dried by hand, including the transducer on the bottom prior to use.

8.3 RS-485 Outputs

The AccUView LED has the capability to operate in one of three different RS-485 modes. Included is a mode for interfacing into the HF Online software package (section **8.3.1** below), and a simple communication mode. A third operating mode is the Modbus communications. All modes will automatically configure and do not require any changes or selections.

8.3.1 HF Online (HF catalog # 19783)

The AccUView LED can operate as a small SCADA system with an optional PC software package, called HF ONLINE. This system allows for an interface with up to 255 AccUView LED's for the purpose of data logging. This system will interface directly with common database and spreadsheet software.

8.3.2 Simple Communication

The AccUView LED can provide basic communications over simple programs such as the Hilgraeve HyperTerminal that is included with most Microsoft Windows packages. The user could also use Visual Basic or other programs. The default communication parameters are 8 bits, no parity and 1 stop bit. These parameters may be changed in the extended CONFIG menu.

The master computer will send out:

- Byte #1 the attention character “:” in ASCII or 3A Hex
- Byte #2 the address of the AccUView LED being queried
- Byte #3 & 4 CR LF or 0D 0A in hex

The AccUView LED will respond with:

- The same attention character “:” in ASCII or 3A Hex
- The address of the AccUView LED
- The Reading
- The Unit (% T or ABS)

A sample communication would look like this:

(Master computer requesting a report from address #1) : 1 CRLF
(AccUView LED set to address #1 Response) :001 97.4 %T

8.3.3 Modbus Communication

Modbus communications is fully operational if the RS-485 option (Catalog #19851A) is installed. The Modbus protocol communication information is covered in a separate manual, Catalog #24570 and is available as a free download from our website at www.hfscientific.com.

8.4 AccUView LED with Flow Alarm (Model 28042)

This model of the AccUView LED has flow switch installed. There is an additional menu in the configuration which gives you the selection of ON or OFF.

A “Low Flow” occurs under 1 Liter/minute and if the flow alarm is enabled will cause a screen indication. The flow alarm can act on both the relays and the 4-20mA. Either relay, if set to Error will change to an alarm state and the 4-20 mA signal will change to 0, 2 or 4 mA (selected by ERLV) unless it is set to OFF. A modbus register is also set. This alarm takes 2-½ minutes of low flow to actuate or restore. Please note that the flow alarm is not sold as an option and cannot be added.



8.5 Remote Panel Meter (Catalog # 19609)

The remote panel meter allows for remote indication of the % T or ABS reading using the 4-20 mA loop. No external power is required as the meter is run off of the 4-20 mA source.

9.0 Routine Maintenance

9.1 Cleaning the Flow Through Cuvette

Measurement cuvettes used for the flow through should be clean and free of marks or scratches. Cleaning is accomplished by cleaning the interior and exterior with a detergent solution and then rinsing several times with distilled or de-ionized water. The cuvette can be replaced by first shutting off the flow using the provided shutoff clamp; unscrewing the old cuvette and replacing with a fresh clean one. Recalibration will be required for accurate operation.

NOTICE

Ensure this cuvette is tightened to the flow through before each operation. After a cuvette it is recommend that the water be run with the flow through not installed to allow for inspection of the seal.

9.2 Replacing or Installing the Desiccant Pouch

The AccUView LED continuously checks the condition of the desiccant. When the desiccant gets in such a condition that it may cause problems, the instrument will display **DESC** on the lower portion of the display to indicate the presence of humidity.

Proper use of the supplied desiccant is essential in maintaining the performance of the instrument. The desiccant has been designed to have a long life; however, replacement of the desiccant pouch will be required from time to time.

It is essential that the enclosure seal on the instrument base be maintained to ensure adequate desiccant life. Inspect the seal each time the desiccant pouch is replaced. Replace or reseal the seal if it is found to be defective.

The desiccant should be replaced when the instrument displays **DESC**. A new sealed desiccant pouch and indicator card are available from HF scientific part #21555R. To initially install or remove the old desiccant, simply unscrew the four corner thumbscrews and remove the electronics half of the instrument. Open the bag protecting the new desiccant pouch and replace (or install) immediately. To speed up the recognition, by the instrument, of the new desiccant it will be necessary to reset the instrument by disconnecting the sensor interconnect cable for 2 seconds and then reconnecting it.

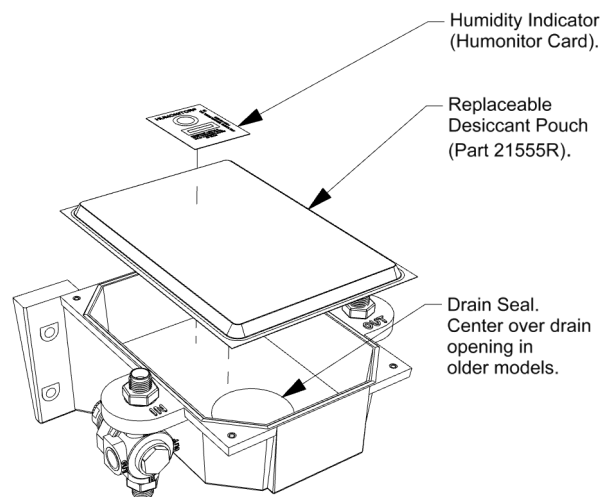

NOTICE

Once the bag is opened, install the desiccant pouch immediately to prevent premature degradation of the desiccant.

9.3 Replacing the Source LED

The UV source lamp in the AccUView LED has a very long life, but is dependent on the setting of the Duty Cycle and operating conditions. See section 7.14 for more information on the LED life

When the UV source LED requires replacement it can easily be performed but it does require opening the enclosure. Contact the factory before servicing. Alternately another service module can be purchased. Call the HF Customer Service Department for assistance.

10.0 Troubleshooting

10.1 AccUView LED Fault Detection

The AccUView LED performs continuous diagnostic monitoring. In the AccUView LED there are three levels of fault detection; warnings, errors and failures. Any faults are displayed in a queue form in the bottom row of the LCD.

A **warning** is simply a screen indication of a problem. No alarms are activated. If the desiccant alarm is turned off and the desiccant becomes saturated, a screen warning of **DESC** will appear. At power-up for 30 minutes and at operating temperatures outside of our specifications, the %T or ABS reading may flash. When this happens the reading may be outside of the stated tolerance.

An **error** indicates a fault or a problem that usually can be corrected by the operator. These errors consist of lamp low output (**LAMP**), 4-20 mA loop open (**MA**), bad 100% T or 0 ABS calibration (**CAL Err**), bad temperature compensation calibration (**TECO**), if desiccant alarm activated and replacement required (**DESC**), if enabled no flow (**FLOW**) (if equipped with the optional flow switch). An additional message will indicate that the ultrasonic transducer is not making contact or the flow through has been removed (**CLN**). If any of these conditions occurs, both alarm relays will be activated and the 4-20 mA output will be held at 2 mA. If any of these errors occur the instrument will still display readings, however the accuracy is not known and the instruments readings should not be trusted.

A **failure** is a system fault. This is NOT a problem that the operator can correct, and the unit must be returned to the factory for service. These failures consist of failures in the CPU, A/D, EEPROM or other devices internal to the instrument (**FAIL**). If a failure occurs, the instrument will not function properly and will display the word FAIL on the lower row, both alarm relays will be activated and the 4-20 mA output will be held at 2 mA (if 4-20 mA is selected).

If any fault conditions occur, the message indicating the fault will be shown on the lower row of the display.

10.2 System FAIL Message

Normally, this condition indicates that the instrument will require servicing. Contact either the HF scientific, Technical Service Department or the HF scientific, Customer Service Department.

HF scientific
3170 Old Metro Parkway
Fort Myers, Florida 33916-7597
Phone: (239) 337-2116
Fax: (239) 332-7643
Email: HF.Info@Wattswater.com
www.hfscientific.com

10.3 Diagnostic Chart

Symptom	Cause	Cure
Lower display shows MA	4-20 mA loop open	Check wiring. See sections 3.3.4 and 7.2
Lower display shows DESC	Desiccant pouch bad	Change desiccant pouch. See section 9.2
Lower display shows LAMP	LED failed	Replace lamp. Refer to section 9.3
Lower display shows FLOW (if flow option installed)	Sample flow has stopped	Restore flow.
Lower display shows CLN	Ultrasonic cleaning failure	Refer to section 8.2
Lower display shows CAL Err after a calibration.	100% T Calibration failure	Refer to section 5.2
Lower display shows TECO	Temperature Compensation Calibration failed	Contact HF scientific service dept. for more information.
Lower display shows FAIL	Major system fault	Refer to section 10.1 & 10.2
Readings are lower than expected	<p>(1) Bubbles in solution</p> <p>(2) Condensate or leaky cuvette</p> <p>(3) Flow through cuvette dirty</p> <p>Instrument out of calibration</p>	<p>(1) Ensure that the drain vent is open and is not obstructed. See section 3.2.2.</p> <p>(2) Apply backpressure. See section 3.2 and figure 4</p> <p>(3) For sever cases of bubbles a stilling chamber is available. Call HF scientific. Part# 20106</p> <p>Check flow through cuvette for condensate or leaks.</p> <p>Clean cuvette. See section 9.1</p> <p>Recalibrate. Refer to section 5</p>
Readings are erratic	<p>(1) Bubbles in solution</p> <p>(2) Debris in flow through</p>	<p>(1) See above</p> <p>(2) Clean debris from cuvette</p>
Readings are lower than expected	Instrument out of calibration	Recalibrate. Refer to section 5

10.4 Technical and Customer Assistance

If for any reason assistance is needed regarding this instrument please do not hesitate to contact either the HF scientific Technical Service Department or the HF scientific Customer Service Department. Contact information is shown on section [10.2](#).

11.0 Accessories and Replacement Parts List

The items shown below are recommended accessories and replacement parts.

Accessory	Catalog Number
Replacement Desiccant Pouch	21555R
100 % T Calibration Solution - 500 ml	19323
Replacement Electronics Service Module	Contact Factory
Replacement Quartz Cuvette with Ultrasonic Transducer	24232S
Operating Manual, AccUView LED	29173
Optional Flow Regulator, 1000ml/min.	19778
Replacement Pressure Regulator	24306S
Replacement UV LED Assembly	28474
AccUView LED Version with Flow Alarm Factory Installed (Provides an alarm if sample flow is interrupted).	28042
Tubing Kit Containing: 1-shutoff clamp, 1-backpressure valve, 2-connecting tubings with fittings for flow through assembly, drain vent.	21062

To order any accessory or replacement part, please contact the HF scientific Customer Service Department. If for any reason technical assistance is needed regarding this instrument please do not hesitate to contact the HF scientific Technical Services Department.

HF scientific
3170 Old Metro Parkway
Fort Myers, Florida 33916-7597
Phone: (239) 337-2116
Fax: (239) 332-7643
Email: HF.Info@Wattswater.com
www.hfscientific.com

12.0 Warranty

HF scientific, as vendor, warrants to the original purchaser of this instrument that it will be free of defects in material and workmanship, in normal use and service, for a period of one year from date of delivery to the original purchaser. HF scientific's obligation under this warranty is limited to replacing, at its factory, the instrument or any part thereof. Parts, which by their nature are normally required to be replaced periodically, consistent with normal maintenance, specifically reagent, desiccant, sensors, electrodes and fuses are excluded. Also excluded are accessories and supply type items.

Original purchaser is responsible for return of the instruments, or parts thereof, to HF scientific's factory. This includes all freight charges incurred in shipping to and from HF scientific's factory.

HF scientific is not responsible for damage to the instrument, or parts thereof, resulting from misuse, environmental corrosion, negligence or accident, or defects resulting from repairs, alterations or installation made by any person or company not authorized by HF scientific.

HF scientific assumes no liability for consequential damage of any kind, and the original purchaser, by placement of any order for the instrument, or parts thereof, shall be deemed liable for any and all damages incurred by the use or misuse of the instruments, or parts thereof, by the purchaser, its employees, or others, following receipt thereof.

Carefully inspect this product for shipping damage, if damaged, immediately notify the shipping company and arrange an on-site inspection. HF scientific cannot be responsible for damage in shipment and cannot assist with claims without an on-site inspection of the damage.

This warranty is given expressly and in lieu of all other warranties, expressed or implied. Purchaser agrees that there is no warranty on merchantability and that there are no other warranties, expressed or implied. No agent is authorized to assume for HF scientific, any liability except as set forth above.

HF scientific, inc.
3170 Old Metro Parkway
Fort Myers, Florida 33916-7597
Phone: (239) 337-2116
Fax: (239) 332-7643
Email: HF.Info@Wattswater.com
Website: www.hfscientific.com

MOUNTING TEMPLATE

ALL DIMENSIONS ARE IN MILLIMETERS (INCHES)

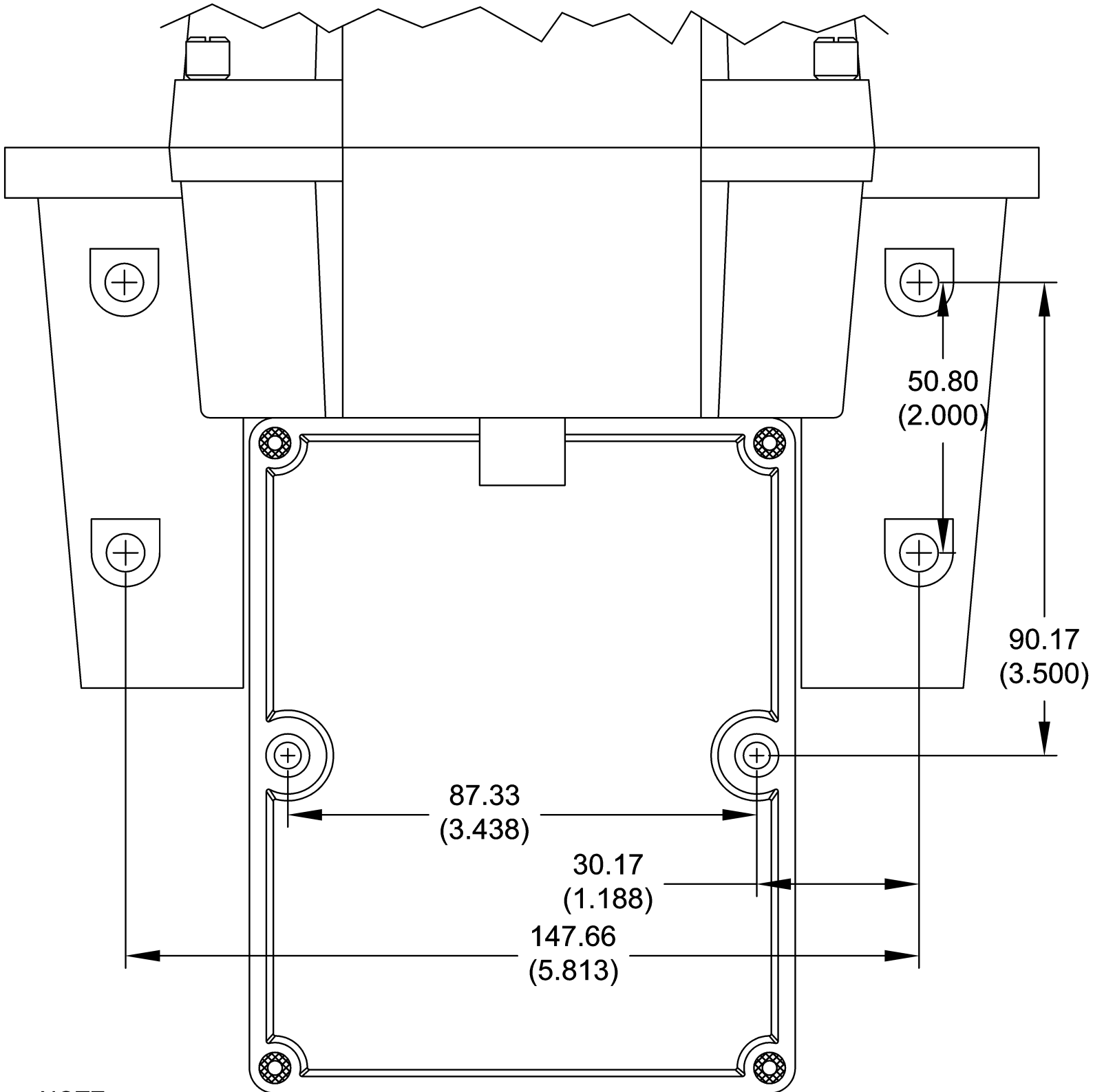

NOTE:

- 1) SEE THE MOUNTING INSTRUCTIONS IN THE MANUAL FOR MOUNTING HARDWARE SIZES.
- 2) PROVIDE AT LEAST 200 MM (8 INCHES) OF FREE SPACE ABOVE THE SENSOR FOR EASY REMOVAL OF THE FLOW HEAD AND INSERTION OF THE CALIBRATION STANDARDS.

